

FDC-2010-TV3

Windows CE® touch panel Computer with 5.6" TFT LCD Display



Features

- **Display:** 5.6" diagonal, 320 x 234 resolution, 65,536 colors, TFT LCD
- **Windows CE.net®** embedded Operating System
- **All in One Platform:**
 Integrated CPU, 64MB DRAM, 64MB RAM & Windows CE.net® OS
- **Fan-less cooling system:**
- **Connectivity ports:** 2-Serial, 2-USB 2.0 and 1-Ethernet (10/100-T)
- **NEMA4/IP65 compliant front panel**
- **Memory:** On board 64MB DRAM, 64MB Flash Memory and One CompactFlash® slot

Introduction

The FDC-2010-TV3 is a compact touch panel computer with embedded Windows CE.net® operating system. Designed to operate in an industrial environment, it combines an affordable operator color touch screen interface with the power and versatility of the open Windows CE® platform.

Windows CE.net®, an open platform, allows versatility to select the HMI software [written for Windows CE], connect to the controllers/PLCs you use and/or create your own application using Microsoft® Visual Basic or 3rd party software development solutions.

The CIRRUS LOGIC EP9315 200MHz processor (CPU) includes a memory management unit (MMU) that supports the embedded open platform Windows CE.net®. The EP9315 CPU also includes a hardware graphics acceleration engine that improves graphic performance by handling block copy, block fill and hardware line draw operations.

Communication Ports: 2-Serial, 2-USB and 1-Ethernet.

Designed to require very low power the FDC-2010-TV2 offers Fan-less operation providing reliable operation & long life.

Environmental Specifications

- Operating temperatures: 0° ~ 45°C (32°F ~ 113°F)
- Relative Humidity: 10% ~ 90% @40°C, non-condensing.
- Shock (operation): 10 to 25Hz (X, Y & Z direction 2G 30 min)
- EMI: Complies with FCC class A
- CE: Complies with EN50081-2 and EN50082-2.
- UL: file # E305816
- Front panel meets IP65 / Nema 4x.

Touchscreen

- Type: 4-wire, analog resistive
- Resolution: continuous
- Light Transmission: above 80%
- Life: 1-million activation minimum

LCD Display

Display type	TFT LCD
Display size (diagonal / W x H)	5.6" diagonal W x H (4.5" x 3.5" / 114 x 89mm)
Maximum colors	65,536
Resolution	320 x 234
Pixel pitch (H x V)	0.362 x 0.118mm
Viewing angle (°)	20/40/50/50 (T/B/R/L)
Luminance (cd/m ²)	500
Storage temperature	-25 ~ 60°C (-13°F ~ 140°F)
Operating temperature	0 ~ 45°C (32°F ~ 113°F)
Backlight	CCFL x 1
Backlight life time	30,000 hrs.
Contrast ratio	150:1

Specifications

- Construction: Polybutylene Terephthalate (PBT) and Polycarbonate (PC)
- Display: 5.6" 320 x 234, 65,536 color TFT LCD (4.5" W x 3.5" H)
- CPU & Core Logic: CIRRUS LOGIC EP9315 200MHz with ARM920T core processor
- DRAM (Dynamic RAM Memory): 64MB
- Storage: 64MB on-board Flash Memory
 1 CompactFlash® card slot
- I/O: 2-Serial Ports: Com1: RS232/RS485 2w/4w
 Com2: RS232 (programming only)
 Com3: RS-232/RS485 2w
 1 Ethernet port (10/100-T)
 2-USB 2.0 full-speed host (12Mbps)
- Sound Output: 20-bits Stereo output.
- RTC: Built-in (Real Time Clock)
- Power Input: 24VDC, 300mA continuous, 1A instantaneous
- Dimension (W x H x D): 204 x 150 x 48mm
 (8.03" x 5.91" x 1.89")
- Weight: Approx. 0.8kg (1.9lbs)

[FDC-200-TV3 Manual v1.0.pdf](#)

<http://futuredesigncontrols.com/fdc-200-TV2.htm>

Dimensions Drawing

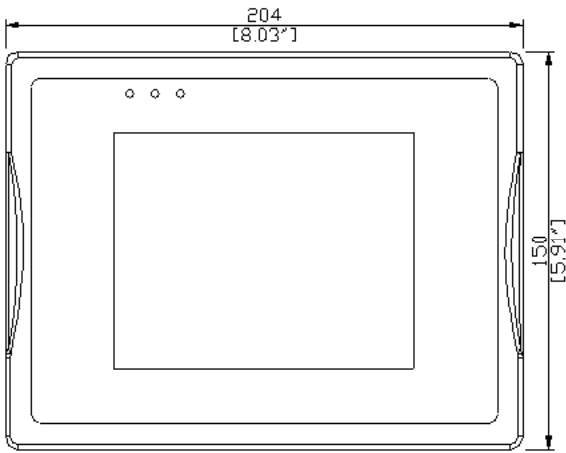

Front View

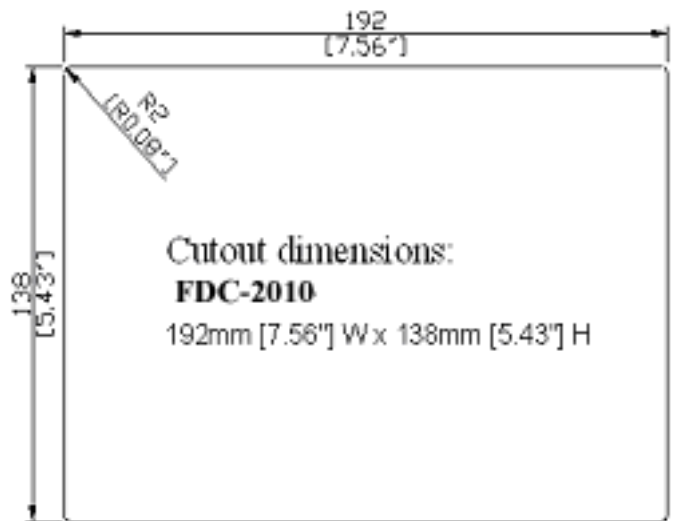

Side View

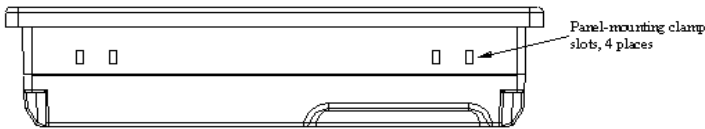

Bottom View

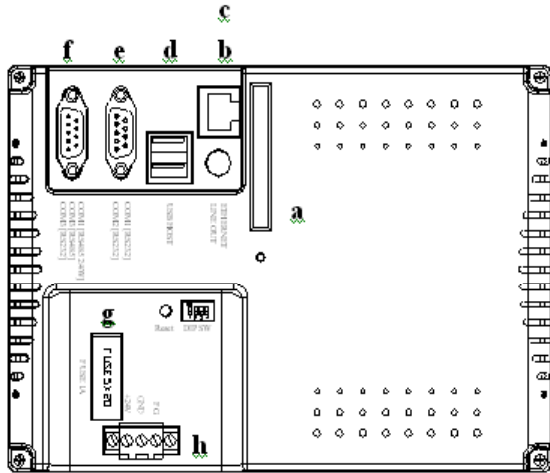
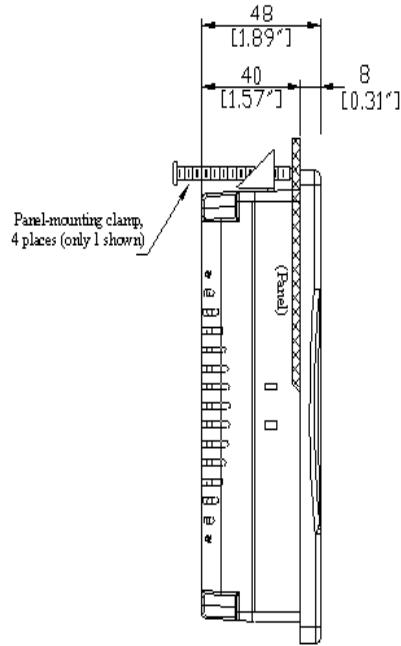

Rear View

a	CompactFlash™ slot	e	Com1[232], Com2[232]
b	Sound ports	f	Com1[422/485], Com3[485]
c	Ethernet port (RJ-45)	g	Fuse
d	USB Host	h	Power connector

Part Number Matrix / Information

FDC-2010-TV3- (1)□□ - (2)□□

Matrix Codes

- 1: Operating System 4.2 (Windows CE OS: 4.2, 5.0 or 6.0)
 2: Special: 00 ("00" characters change to define special)

Accessories: Partial List below; complete list [FDC-200_Accessories.pdf](#)

PS2010: Display Protective Sheets (5/package)

Power Supply- DIN Rail Mount: [PSR-SD24](#) (85-264 VAC in/24VDC 60W out)

Cables: Configuration Cable: DB9M-DB9F-6ft

Power Cable: CA-PWR-18AWG_2conductor_shielded_no_terminals

Display to PLC cables: Refer to: [FDC-200-PLC_cable_selection.pdf](#)

Refer to [FDC-200_Accessories.pdf](#) for following:

Ethernet CAT5E Patch & Crossover Cables 7ft to 100ft – see acc list

USB 6ft cables & Extension 16 ft cables

USB Panel Mount Adapters: Standard & Nema 4X

[FDC-200-TV3_Manual_v1.0.pdf](#)