



Orion-M SR

FDC 300 Series Controller System Guide



Safety Information in this Manual

Notes, cautions and warnings appear throughout this book to draw your attention to important operational and safety information.

A “**NOTE**” marks a short message to alert you to an important detail.

A “**CAUTION**” safety alert appears with information that is important for protecting your equipment and performance.

A “**WARNING**” safety alert appears with information that is important for protecting you, others and equipment from damage. Pay very close attention to all warnings that apply to your application.



This symbol (an exclamation point in a triangle) precedes a general CAUTION or WARNING statement.



This symbol (a lightning bolt in a lightning bolt in a triangle) precedes an electric shock hazard CAUTION or WARNING safety statement.

Technical Assistance

If you encounter a problem with your Orion-M controller, review all of your configuration information to verify that your selections are consistent with your application: inputs; outputs; alarms; limits; etc. If the problem persists after checking the above, you can get technical assistance by dialing +1 (866) 342-5332 or by faxing your request to +1 (866) 332-8014, Monday thru Friday, 8:00 a.m. to 5:00 p.m. Eastern Standard Time. You can also email your request to support@futuredesigncontrols.com.

An applications engineer will discuss your application with you.

Please have the following information available:

- Complete Model #'s and/or Serial #'s for Component(s) in Question
- Complete Software Version #'s
- All Configuration Information
- All User Manuals

Warranty and return information is on the back cover of this manual.

Your Comments

Your comments or suggestions on this manual are welcome. Please send them to:
Future Design Controls, P.O. Box 1196, Bridgeview, Illinois, 60455
Telephone: +1 (888) 751-5444; fax: +1 (888) 307-8014
csr@futuredesigncontrols.com

The Orion-M FDC 300 Series Controller System Guide is copyrighted by Future Design Controls, Inc., © 2009, all rights reserved (<http://www.futuredesigncontrols.com/Orion-M.htm>).

1	What is the Orion-M?	1.1
1.1	Features.....	1.1
2	Getting Started	2.1
2.1	Installing the FDC 300 Series Controller	2.1
2.1.1	<i>Communications Wiring</i>	2.1
3	Configuring the FDC 300 Series Controller	3.1
3.1	Assigning the Proper Communications Settings	3.1
3.2	Input Type Assignments	3.2
3.2.1	<i>Input 1 Operation</i>	3.2
3.2.2	<i>Input 2 Operation</i>	3.2
3.3	Control Output Assignments	3.3
3.3.1	<i>Auto-Tune and Auto/Manual Operation</i>	3.3
3.4	Loop Permissions	3.4
3.4.1	<i>Set Point Permission Exception</i>	3.4
3.4.2	<i>Auto Tune Permission Exception</i>	3.4

Appendix

Order Matrix and Replacement Parts
Software License
Software Usage Note
Warranty
Returns

1 What is the Orion-M?

The Orion-M is a multi-loop process control system combined with an embedded SCADA color touch interface. The Orion-M provides a configurable control platform for a variety of OEM applications requiring up to 15 separate loops of control. In addition to 15 loops of control, the Orion-M can also provide up to an additional 15 inputs for process monitoring, for a total of 30 process inputs.

The system is provided with eight 24Vdc digital inputs, two 24Vdc outputs and 6 relay outputs standard. The Orion-M can be expanded to a total of 16 digital inputs and 32 digital outputs. The Orion-M also provides the capability of accepting analog inputs for remote set point control and analog outputs capable of retransmitting system variables (PV, SP or %Out) to other devices such as a chart recorder. The 0-10Vdc or 4-20mA user selectable signals are provided through the addition of optional analog expander cards.

The Orion-M complements its versatile hardware platform by providing a host of standard features and configuration capabilities, all through its visual, touch interface. The touch screen interface is an embedded, industrial PC with all software included. No external PC software is required for setup or configuration of the Orion-M. All of the setup and configuration data is saved to the Orion-M's internal memory.

Individual process controllers, one for each loop in the system, provide reliable, consistent and accurate control by distributing the process control requirements of the system among multiple processors. Each loop controller provides full auto tune functionality with high resolution, universal process inputs. When coupled with the built in ramping profiler of the Orion-M, it allows for automatic, timed control of all processes and outputs of the system. No other control system on the market provides the flexibility, functionality and configurability of the Orion-M.

1.1 Features

The digital inputs of the Orion-M can be configured as alarm inputs with adjustable delay timers, as control inputs for controlling profile operation or for direct control of the system's digital outputs.

The digital outputs of the Orion-M can be used as direct outputs for controlling external equipment related to the application through software switches, called events, or be programmed to act as system alarm or status outputs. All outputs have adjustable delay times for on, off and cycle times.

The Orion-M can be operated in single set point or automatic profile control mode. Profile entry is made easy through the use of copy, paste and delete menu selections. Profiles can be copied to the external 'USB' memory stick and then imported to another Orion-M controller which eliminates the need to enter duplicate profiles into multiple Orion-M systems. When running in automatic profile mode, the operator can place the system into hold and change any control parameter without modifying the saved profile. This gives the operator maximum flexibility over the controlled process.

Data file analysis tools (auto-trend) make looking at historical data a simple task. Any control variable saved to the Orion-M flash memory can be plotted on the historical data trend, for any time frame within the data file's total time range. Full 'USB' print capabilities from the Orion-M interface to a standard HP inkjet printer Model 6540, 6940, 6980 (or compatible printer), eliminates the need for a PC, strip or circular chart-recording device. Graphics trends, historical and report print functions are standard.

The built in Ethernet functionality includes a 'Web Server' to provides access to all Orion-M data (view only), a VNC interface for remote control and monitoring and an NTS clock, all available via a local Intranet connection (wired or wireless), or the World Wide Web using standard software like Microsoft's Internet Explorer.

The Orion-M provides a rich set of tools for control interaction and data analysis. Views include system overviews, trends, alarms, profiles as well as historical data, alarm history and audit trail views. The menu driven interface eliminates screen 'clutter' by providing an easy to use 'Windows' interface for interaction between the user and the Orion-M system.

The Orion-M can store more than one year of data on its internal compact flash card. Data logging can be enabled manually or automatically during automatic profile run. Data backup is provided with the 'USB I-Stick' for plug and play transfer of files to any PC running Microsoft Windows XP operating systems.

The Orion-M security module provides full system security with three levels of access. Each of the three access levels allow for independent user rights. Up to 30 users can be entered into the system while the audit trail tracks all operator actions and records them.

The Orion-M control system includes the following interface features:

- Overview screen that displays all "runtime" information.
- Profile run and monitor views.
- Profile entry, open, save and download interface screens.
- Current alarm and alarm history views (alarm history for up to 1 year).
- Real time trends (with adjustable X,Y limits) for all inputs.
- System and application setup (control loops, monitors, inputs/outputs, alarms, etc.).
- Data logging interface screens include log point selection and historical viewing.
- 'Plug and Play' memory stick functionality for data transfer/backup.
- Full USB print capabilities and on-line help screens
- Web server for intranet/internet access (view only).
- VNC server for intranet/internet access (control/view).
- FTP data back-up for automatic data file transfer over intranet/internet.
- Integrated email server for alarm notification and file transfer.
- NTS clock with daylight savings time insures that the system is up to date.
- Full security with audit trail for tracking user actions.
- Maintenance counters for output cycles and on times.
- Helps screens are available for most screen views; configurable in English, Spanish and French
- Voice assisted help in English, Spanish and French (external speakers required – not included).

2 Getting Started

The Orion-M requires one FDC 300 Series for each control loop required in the system. Since the Orion-M is capable of interfacing to more than one brand of controller, refer to the Orion-M part number matrix for the operating system to be sure that the FDSR CM application software has been provided. The Orion-M will not operate correctly if any other version of CM application software is used with an FDC 300 Series controller.

2.1 Installing the FDC 300 Series Controller

For applications requiring several loops of control or more, proper planning and arrangement of the 300 Series controllers prior to mounting is critical for optimum routing of the controller wiring. For applications requiring frequent access to the controllers, panel mounting provides direct access. For applications where operator access to the controllers is not required, or is desired to be kept at a minimum, the controllers can be mounted directly inside of an enclosure. This also reduces wiring concerns by eliminating the need to run the sensor, communication and control wiring for each controller to and from an enclosure door.

Refer to the user's manual for the 300 Series control being used for dimensions, appropriate mounting and operating conditions, including proper electrical connections. Connect sensor and control wiring as required, paying close attention to all wiring precautions and guidelines as noted in the controller manual. It is recommended that all sensor and communication wiring, to and from the 300 Series controllers, be routed away from all high voltage and/or output control wiring. This will minimize the chances of electrical transients or spikes in the power/control wiring from causing communications or sensor reading errors.

2.1.1 Communications Wiring

Each FDC 300 Series control used in the Orion-M system is its own independent loop control. However, in order for the controllers to work as part of the system, they must communicate with the Orion-M control module using RS485 serial communications. Therefore, each 300 Series used must be equipped with the RS485 communications option or they will not operate as part of the Orion-M system:

```
FDC-9300- X X X X X 1
FDC-8300- X X X X X 1 X
FDC-4300- X X X X X 1 X
```

└─ Order code 1 designates RS-485 Modbus RTU serial communications
(see particular 300 Series User's Manual for order code descriptions)

Communications wiring must be run using a minimum of 24 AWG twisted-pair, copper conductors. For short runs (< 50 feet total), non-shielded wiring can be used as long as proper separation from power/control conductors is maintained. For communications wiring where the total length will exceed 50 feet, up to the maximum allowed length of 650 feet, shielded twisted-pair must be used.

NOTE: FDC recommends the use of shielded wire for all installations regardless of the total length in order to maintain optimum performance and minimize the possibility of communications errors.

When using shielded twisted-pair, be sure to ground the shield at only one end, preferably at the Orion-M control module. Allowing any other portion of the cable shield to come in contact with ground, or grounding both ends, will allow ground loop currents to flow in that section of the cable shield which can disrupt communications.

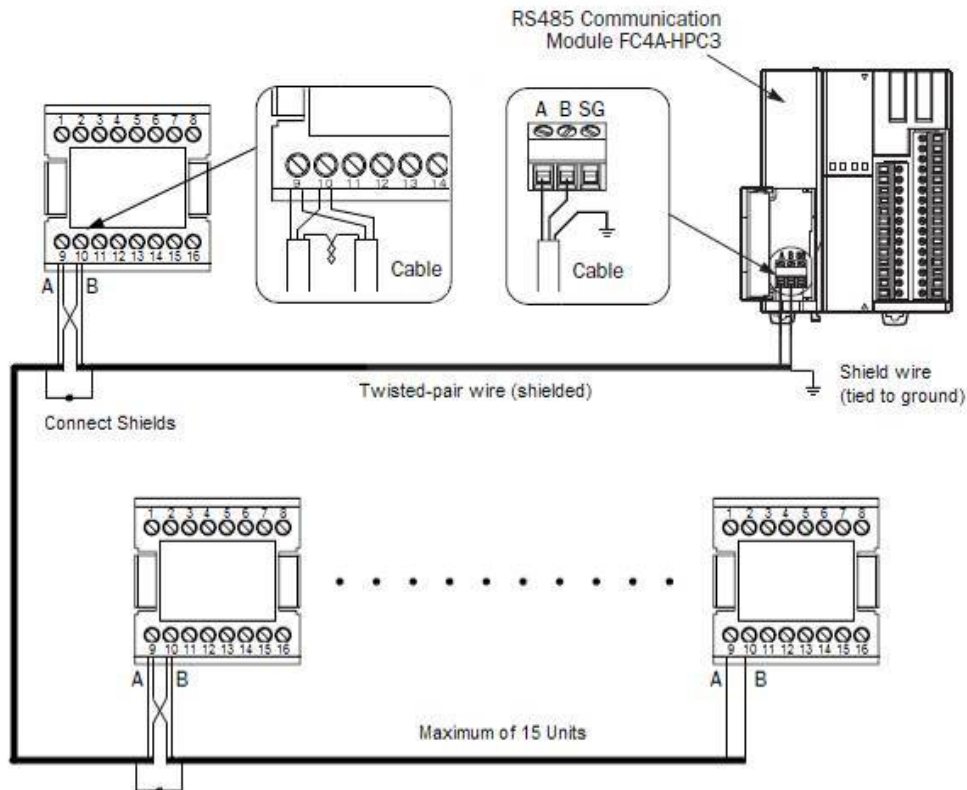

Communications Wiring Example (FDC-9300 controller shown)

Communications wiring to the FDC8300/4300 series will be done in the same manner as that shown above for the FDC-9300 controller except the communications connections are made to different terminals as shown below.

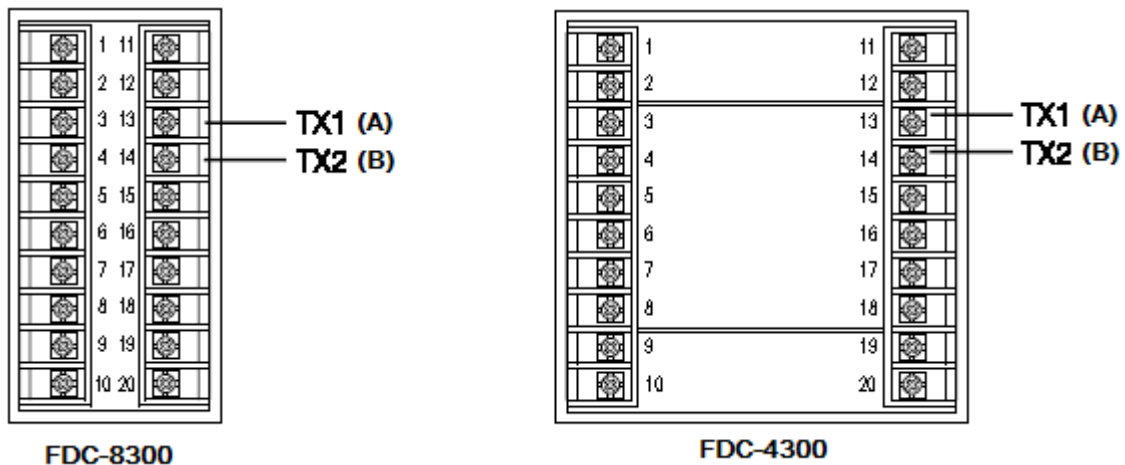

NOTE: Refer to the User's Manual for the 300 Series controller used for all other connections including power, sensor and control wiring. Since no two applications are the same, it is up to the system designer to insure that the controllers are properly installed and wired to meet design specifications.

3 Configuring the FDC 300 Series Controller

The unique and inherently flexible design of the Orion-M system allows the OEM to tailor each component of the system to the application. By using independent loop controls, each one can be configured for various input and output types, control algorithms, etc., based on the requirements of the application. It also allows control loops to be added or replaced on the system at any time, simply by connecting the controller to the Orion-M's control module, RS-485 communication link.

If the application requirements change and a different input or output type is required, or if the controller were to fail, it can be replaced quickly, and at a lower cost as compared to having to repair or replace larger, integrated multi-loop controllers. The Orion-M only requires that the communications settings for each loop control be properly assigned, and that the input type of the controller is set in the Orion-M Configurator, so that the control loop input and set point can be displayed and set properly through the Orion-M interface.

3.1 Assigning the Proper Communications Settings and Set Point Parameters

The Orion-M can support up to 15 FDC 300 Series controls. They can be mixed and matched as required, but each one must have its own communication address. The allowable address range is 1 – 15 corresponding to Loop Input #1 – 15 in the Orion-M Configurator. Communication addresses must be assigned to all controllers on the communications link beginning with 1, up to the total number of controllers. As control loops are enabled in the Orion-M Configurator, the Orion-M will automatically use the Loop Input # as the corresponding controller address. If more than one 300 Series controller has the same address, or a loop input is enabled but a controller is not assigned to that address, the Orion-M will report a communications alarm for that loop input when the runtime application is started.

NOTE: *The order of the loop controls on the communication link is not important. The communications address for a controller can be assigned regardless of its position on the link.*

In addition to the communications address, the baud rate, data bits, stop bits and parity settings must also be set to match the control module of the Orion-M. The Orion-M uses the factory default communication rate of 9600 baud, 8 data bits and 1 stop bit; however, the parity of the 300 Series controller must be changed from the factory default of 'even' to 'none'. The function level of the control must also be set to 'FuLL'. This permits the Orion-M's control module to access the necessary data values within the 300 Series Control. If the function level is left in the basic (bASC) mode, communication errors will result. The Orion-M SR features also require that the loop control's set point parameter be assigned to ramp rate in degrees/hour. If this is not set correctly, the set point ramp rate will not work according to the ramp rate entry.

**Required 300 Series Controller Settings for Proper Communications:*

- Function complexity level (Func): FuLL
- Communication interface type (Conn): 485
- COMM protocol selection (Prot): rtu
- Address assignment of digital COMM (Addr): 1-15 (*based on system design*)
- Baud rate of digital COMM (bAud): 9.6
- Data bit count of digital COMM (dAtA): 8bit
- Parity bit of digital COMM (PAri): none
- Stop bit count of digital COMM (StoP): 1bit
- Set point mode selection (SP.nd) Hr.r

***See section 1-5 Menu Overview, in the 300 Series User's Manual for instructions on accessing the control's Setup Menu and setting the above parameters as required.**

3.2 Input Type Assignments

The FDC 300 Series controls provide a universal input for input 1 and an analog input (voltage/current) for input 2. The Loop Input # for the corresponding control in the Orion-M Configurator is set to match the selected input type for input 1 of the 300 Series control. Based on this selection, the Orion-M assumes control of certain parameters related to the input and automatically assigns them based on settings made in the Orion-M.

3.2.1 Input 1 Operation

When input 1 of the 300 Series control is set for a temperature input type, i.e., RTD or thermocouple, the corresponding Loop Input # in Orion-M Configurator must also be set to temperature. When these selections are made, the Orion-M will automatically set the temperature units of the control to match the temperature units (degrees C or F) set in the Orion-M. If the Orion-M loop input type is set to process in the Configurator for a temperature input type, the Orion-M will change engineering units for the input; however, the units in the 300 Series control will not be set to match by the Orion-M. Therefore, the Orion-M may display units in degrees Fahrenheit while the reading is in degrees Centigrade or vice versa.

When input 1 of the 300 Series control is set for an analog input type, i.e., voltage or current, the corresponding Loop Input # in Orion-M Configurator must be set to process even if the input is from a temperature transmitter. The range and units of the temperature transmitter are unknown to the Orion-M so they must be manually set at the 300 Series control. If the Orion-M loop input type is set to temperature in the Configurator for an analog input type, the Orion-M will change engineering units for the input; however, the measurement will not change. Therefore, the Orion-M may display units in degrees Fahrenheit while the reading is in degrees Centigrade or vice versa.

For either temperature or analog input types, the Orion-M will set the decimal point and lower and upper set point limits for the input to match the settings in the Configurator. The decimal point and set point limits must match in order for the system to operate properly and display the correct values on the Orion-M interface.

IMPORTANT: *The temperature units, decimal point and lower and upper set point limits are set once, each time the Orion-M enters the runtime application. Do not alter the values in the 300 Series control once they have been set or the Orion-M will not display the correct process value or set the correct set point to the loop control which could result in a runaway condition leading to property damage or injury to personnel.*



3.2.2 Input 2 Operation

Input 2 of the 300 Series controllers can be used as monitor inputs to the Orion-M. When Loop 2 Input is selected as the monitor input type in the Orion-M Configurator, the Orion-M will display the second input of selected loop controls as monitor inputs.

When using the second input of control loops for monitor points, it is important to note that the controller itself, provides range, calibration and input bias settings for the input. The range and units of the transmitter are unknown to the Orion-M, so it will not automatically set these values based on settings in the Configurator. The input 2 values are set manually at the loop control.

In order for the Orion-M to properly read and display the value correctly, the decimal point setting for the monitor input in the Configurator must match that of the loop control for input 2. If the decimal point settings do not match between the Orion-M and the loop controller, the Orion-M will not properly read or display the value of the second input for the monitor point.

When degrees C or degrees F is selected from the Degrees C/F screen in the Orion-M runtime application, engineering units for temperature of 'C' or 'F' are automatically updated for all loop and monitor points. If input 2 of the loop controller is a temperature reading in degrees F for example (from a temperature transmitter), and degrees C is selected on the Orion-M, the monitor point reading will be a value in degrees F, but the units shown will be in degrees C.

To prevent the units from being changed, the Degrees C/F settings screen in the runtime application can be hidden to prevent changes (see Section 3.6 Orion Functions/Startup View) or even password protected in the runtime application. The engineering units could also be entered as 'dgC' or 'dgF' for example. The Orion-M will then ignore them for a degrees C or degrees F units change.

It is important to insure that the engineering units match the loop control for input 2 to avoid operator confusion and prevent the misinterpretation of the value.

The 'Monitor Input Offset' screen in the Orion-M runtime application allows an offset to be applied to the monitor points when input 2 of the loop controls are used. However, the input offset of the Orion-M only corrects the value shown on the Orion-M and does not offset the reading in the loop control.

If the loop control is visible to the operator, it is recommended that the 'Monitor Input Offset' screen be hidden (see Section 3.6 Orion Functions/Startup View in the Orion-M Configuration Manual) or even password protected in the runtime application to prevent an offset from being applied to the monitor point in the Orion-M. Rather, use the input bias setting of the loop control so that both the reading on the loop control and the Orion-m will match to avoid operator confusion.

NOTE: *If there is an input error for input 2 of the 300 Series controller, the alarm will be reported on the Orion-M Alarm Monitor screen as a sensor break alarm the loop control, not as a sensor break for the monitor point.*

3.3 Control Output Assignments

The 300 Series controls have two control outputs that can be assigned to operate as heat/cool (indirect/direct). If only a single control output is used (output 1), for heating or cooling operation, the Orion-M will display a percentage of output of 0.0 – 100.0% for the output.

If both outputs are used in a heat/cool application (output 1 is heat and output 2 is cool), the Orion-M will display a value of -100.0% to 100.0% for the percentage of output. In this case, 0.0% represents both heat and cool outputs are off. Values from 0.0 to 100.0% represent the percentage of heat output from off to full on and values from 0.0 to -100.0% represent the percentage of cool output from off to full on.

3.3.1 Auto-Tune and Auto/Manual Operation

The Orion-M provides the ability to switch each 300 Series control in the system between auto and manual output operation as well as initiating the controller's auto-tune function. These functions are accessed from the Orion-M runtime, Single Loop View screen via the 'AM' and 'AT' control buttons.

As long as the output is not programmed for on/off control, i.e., the proportional band is set to zero (0), these functions will be available. If the proportional band of the control's PID parameters is set to zero; however, the auto-tune and auto/manual selections will be disabled.

3.4 Loop Permissions

The Orion-M iSeries configuration provides permissions which can be set to allow the control loop set point, auto/manual and auto tune operations to be performed at the loop control itself as well as through the Orion-M. These can allow an operator to make changes at the loop control in cases where the Orion-M interface is located in a remote location.

3.4.1 Set Point Permission Exception

If the control loop is configured to operate under cascade control or is configured as an RH wet bulb loop type, the set point for the loop is generated by logic within the Orion-M. The loop will not function as configured unless the set point is constantly set by the Orion-M. Thus, any change made at the loop control will be overridden by the Orion-M. If local adjustment at the loop control may be required for any reason, loop set point communications must be interrupted via a digital input to the Orion-M configured as 'loop SP comms disable'.

3.4.2 Auto Tune Permission Exception

If the control loop is configured to operate under cascade control or is configured as an RH wet bulb loop type, the set point for the loop is generated by logic within the Orion-M. This set point may constantly fluctuate in order to provide the proper control action. The 300 Series controller will abort the auto tune process if its set point is changed while it is auto tuning. Thus, if auto tune is initiated at the loop control and the Orion-M is sending a new set point, the auto tune will be immediately aborted.

When auto tune is activated at the Orion-M, the set point is first 'locked in' prior to initiating the auto tune. This prevents the set point from being changed if the loop is a wet bulb type or under cascade control once auto tune is activated. The Orion-M will maintain the current set point at the loop control regardless of process changes until the auto tune completes.

Appendix

Order Matrix: FDC Orion-M SR-

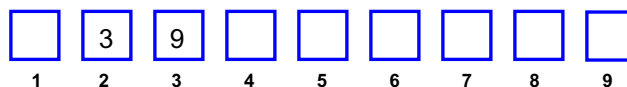

1. Graphic User Interface (GUI) & Control Module (CM)

- 2: FDC-2107i Windows CE 7" iSeries Color Touch Screen
 3: FDC-2110i Windows CE 10" iSeries Color Touch Screen

Control Module (CM) includes the following components:

- FC5A-D16RS1: Control Module CPU with on-board 8-digital input (24Vdc) and 8-digital outputs (6-relay/2TTL)
- FC4A-PM64: 64KB Memory Card
- FC4A-PT1: Real Time Clock
- FC4A-HPC3: Modbus port (connect loop controls to FC5A CM)
- CA2011-8A: Cable from FC5A CPU to display (8ft)
- GE1A-C10MA110 / SR2P-06: Reset Timer and socket (DIN Rail)
- 2GB SD Memory Card (holds Orion-Mi application software)
- 2GB High Capacity USB Memory Stick (3VDC)
- PS5R-SD24: Power Supply (Input 85-264Vsc/Output 24Vdc 60 Watt (2.5 amp))

2. Graphic User Interface (GUI) Application Software

- 2: FDCI: standard iSeries software for 7" and 10" displays
 3: FDSR: SR iSeries software for 7" and 10" displays

3. Control Module (CM) Application Software (loop control type)

- 1: FD10: CM software for FDC 100 Series
- 2: FD30: CM software for FDC 300 Series (note 2)
- 3: HWSL: CM software for Honeywell 2500/3200 (note 2)
- 4: HWDL: CM software for Honeywell 3500 (note 3)
- 5: WTSD: CM software for Watlow SD
- 6: WTPM: CM software for Watlow PM
- 7: DHPL: CM software for Danaher West/Partlow Plus
- 8: YKGS: CM software for Yokogawa UT Green Series
- 9: FDSR: CM software for FDC 300 Series Orion-M SR (note 2)

Software - Future Release

- YKXX: CM software for Yokogawa UT Advanced
- ER20: CM software for Eurotherm 2000 Series
- ER30: CM software for Eurotherm 3000 Series
- ERM8: CM software for Eurotherm Mini 8 Series

4. Monitor Inputs (Note 2) (DIN Rail Mount – serial connection to CM)

- 0: None
- 1: IO-8TCS: (8-thermocouple input module - isolated)
- 2: IO-6RTD: (6-RTD input module)
- 3: IO-8AIIS: (8- input module 0-20 / 4-20mA - isolated)
- 4: IO-8AIVS: (8-analog input 0-10 / 2-10Vdc—isolated)
- 9: Special

4. Digital Inputs (Note 1) (DIN Rail Mount – plug into CM)

- 0: None
- 1: FC4A-N08B1: (8-digital input card (24Vdc))
- 2: FC4A-N08A11: (8-digital input card (120Vac))

Note: The above optional digital inputs (DI) are in addition to the eight 24Vdc digital inputs that are standard on the CM; system maximum of 16 digital inputs.

Note 1: CM will support up to 7 expansion modules (the monitor point input module is not a CM expansion module).

Note 2: When specific CM application software is specified and system is configured to monitor input#2, matrix code #4 (Monitor Points) must be None.

Note 3: Dual loop HW3500 is limited to 7 controls maximum (14 loops) compared to 15 loops for other single loop controls.

6. Digital Outputs (DIN Rail Mount – plug into CM)

- 0: None
- 1: FC4A-T08S1 (8-digital output– TTL 24Vdc (source))*
- 2: FC4A-R081 (8-digital output - Relay (240Vac 2-amps))
- 3: FC4A-T16S3 (16-digital output– TTL 24Vdc (source))*
- 4: FC4A-R161 (16-digital output - Relay (240Vac 2-amps))

Combination DO modules (maximum of 24 optional DO)

- A: Item 1 / qty 2
- B: Item 1 / qty 3
- C: Item 2 / qty 2
- D: Item 2 / qty 3
- E: Item 1 qty 2 & Item 2 qty 1
- F: Item 1 qty 1 & Item 2 qty 2
- G: Items 1 & 3
- H: Items 1 & 4
- J: Items 2 & 3
- K: Items 2 & 4

*The terminal blocks for all of the above are inclusive except for the FC4A-T16S3, 24Vdc output card, whose terminal block is a separate component, part number FC4A-PMPC20P. This terminal block is included as a separate component when specifying this output card.

Note: The above optional digital outputs (DO) are in addition to the 8 DO that are standard on the CPU (6 relay & 2 TTL 24Vdc); maximum of 32 DO.

7. Analog I/O (Note 1) (DIN Rail Mount – plug into CPU)

- 0: None
- 1: 1 A-IO card FC4A-L03A1 (4-20mA or 0-10Vdc IO)
- 2: 2 A-IO cards FC4A-L03A1 (4-20mA or 0-10Vdc IO)
- 3: 3 A-IO cards FC4A-L03A1 (4-20mA or 0-10Vdc IO)
- 4: 4 A-IO cards FC4A-L03A1 (4-20mA or 0-10Vdc IO)
- 5: 5 A-IO cards FC4A-L03A1 (4-20mA or 0-10Vdc IO)
- 6: 6 A-IO cards FC4A-L03A1 (4-20mA or 0-10Vdc IO)
- 7: 7 A-IO cards FC4A-L03A1 (4-20mA or 0-10Vdc IO)

Note: Each I/O card has qty 2 Remote Setpoint input and quantity 1 Retransmission output configurable for PV,SP or %Out

8. Serial Communication (Note 1) (DIN Rail Mount – plug into CM)

- 0: None
- 1: FC5A-SIF4 (RS485 Modbus RTU port (slave))* (port 3)
- 2: FC5A-SIF2 (RS232 port for Barcode Reader) ** (port 4)

Note: If Item 2 is specified, Item 1 is included and must be counted in the total number of modules.

*RS485 Modbus RTU port allows R/W access to 3rd party software.

**Bar Code Reader input is compatible for serial based barcode readers. System will accept up to 16 characters of data from the bar code scanner. Data from the bar code reader will be inserted as operator events in the Historical Data File; there is no limit to the number of events that may be entered manually or with a bar code scanner.

9. Special

- 0: None
- 1: CM Assembled & wired on DIN Rail

Sample Part Number

FDC Orion-M-2-2-2-1-1-4-0-0-0
 GUI 7" display, FDCI (standard Orion-M iSeries) software, CM software for FDC 300 Series loop controls, Monitor input card (8-T/C inputs), 8 additional DI, 16 additional DO, no analog I/O, no serial communications and no special functions

NOTES: SCADA (Supervisory Control & Data Acquisition)

FDC-Orion-M iSeries Graphic User Interface (GUI) is available in 7" and 10" color touch screens. The GUI provides a full SCADA feature set providing ease of use, data acquisition, alarm manager, operator audit trail, multi-level Security with user rights, LAN connections and more.

The GUI provides ease of configuration, use & support.

- System Configuration for loop, monitor point, alarm, digital input & outputs assignment / logic, Help language selection and more, all without an external device or PC.
- Loop Views: multiple view Loop and/or Monitor Points in single or All View; Trend, Bar Graph and Digital views also available
- Profile: Virtually unlimited number of profiles with each profile having up to 99 steps with up to 32 events.
- File Management: View, print, copy/move Profile, Alarm, Historical Data (data log files) and operator audit trial files. File transfer via LAN features or USB flash memory.
- Support: View loop & digital IO status, force loop & digital outputs and more.
- Print: Print directly from GUI via USB port
- LAN: Remote Access & touch screen operation (VNC), email/SMS on alarm, email historical, alarm & audit trail files on-demand, Web Page (view only) and FTP of historical data files automatically or on-demand.

Data Acquisition:

- Data log up to 15 control loops (PV, SP & % out) & 8 Monitor Points (specific dual input loop controls may allow up to 30 PV inputs)
- Log interval: configurable 6 seconds to 31 minutes with configurable number of days to auto start & name next file (1 to 31 days).
- File Start/Stop: Configurable; operator on-demand, on system boot, profile ramp-soak start/end or digital inputs
- File Interval: Once started a data log file is configurable to auto end and start new file with the same name as previous file with an appended time/date name. Configurable time interval is from 1 to 31 days.
- File name: Operator entered file name, batch & lot number or if running a profile, file name same as profile name. (all file names appended with date-time to file name)
- Operator Comments/Events: Unlimited operator comments/events linked to each file entered manually or via Bar Code Scanner.
- Digital Signatures: full support for user based digital signatures for each data file (data encryption).
- Historical Data File: View & print the data directly from the display (auto scale on X & Y axis with each channel selectable for right or left axis values), from a PC after data is copied/moved via LAN (FTP or email) or USB Flash Memory card provided.

NOTES: Monitor Inputs – Optional

Monitor Inputs:

The FDC-IO modules are DIN rail mount 8-channel isolated thermocouple, RTD (6-channel) or 8-channel linear mA or Vdc input modules. Each monitor point is configurable for Alarm setpoints and segment advance "wait for" logic (SP logic & loop Delta function).

Information on the FDC-IO modules may be found at the following link: http://www.futuredesigncontrols.com/FDC-IO_Modules.html

Note: When CM Application Software FD30 or HWSL is specified and system configured to monitor loop input #2, Monitor Input I/O module will not be active.

NOTES: Power Supply – Standard (DIN Rail Mount)

Power Supply:

DIN Rail mount 24VDC 60 watt power supply (2.5-amps) to power the FDC-2010 GUI, control module CPU, optional IO and FDC-IO monitor input modules.

NOTES: Configurable Control Logic

Ramp/Soak Profiles (Global Profile configurable as Time or Ramp Rate based): The FDC-Orion-M provides for a virtually unlimited number of profiles each with up to 99 steps and up to 32 configurable events per step. Step Advance, Hold, Stop, and other "Wait For" logic per step is standard. The "Wait For" step advance logic includes digital inputs, loop / monitor points achieving a "wait for SP" and Delta SP logic.

Configurable Loop Control:

Each of the DIN control loops may be configured via the operator interface as single loop controls or as components in Cascade or %RH values. Each control loop is configurable to run Ramp/Soak profiles or as steady state controls (non-profile) per profile.

Alarm Configuration:

System Alarms

System Alarms include loss of communication with loop & monitor points, configurable call back, audible and more; may be mapped to one of the standard or optional digital outputs

DIN Control Loop Alarms (a maximum of 30 alarms for loop & monitor)

The loop controls (up to 15) may have up to 30 alarms configured per loop. The alarms may be configured as soft/audible, latching or not, inhibit logic and to defeat any digital output. Alarms may be mapped to one or more of the standard or optional digital outputs (maximum of 32 digital outputs). Alarm types include:

- Process, Deviation, Percent Output and Rate of Change (ROC) low, high or both

Monitor Input (a maximum of 30 alarms for Loop & monitor)

Each channel may be configured with Process or Rate of Change (ROC), soft/audible, latching or not, inhibit and/or to defeat any digital output. Alarms may be mapped to one or more of the standard or optional digital outputs (max of 32 digital outputs)

Digital IO Configuration

Digital Outputs (DO): CPU includes 8-digital output (6-relay & 2-TTL) with optional 8 & 16 output cards (24VDC or relay); max of 32 DO.

DO are configurable as:

- Loop, monitor point or digital input alarms
- Event outputs used in ramp soak profiles
- Event output for profile status: run, hold & step change
- Event outputs as a result of Digital Inputs
- Configurable cycle times to pulse an output or no cycle - on 100%
- Configurable time delay to automatically turn DO off
- Configure DO with counter & alarm message

Digital Inputs (DI): CPU includes 8-digital inputs with optional 8- digital input card for maximum of 16 digital inputs.

DI may be configured:

- Configurable time delay (timers)
- System Run
- Alarm Input
- Data Acquisition start and stop
- Profile functions; start, stop (all off), hold, advance previous/next step
- Defeat Logic; disable specific or groups of DO
- Disable Communication to loop controls SP or All components
 - SP communication disabled: SP values may be changed at loop controls while still monitor & data log all values.
 - All communication disabled: SP values may be changed at loop controls but no loop, monitor alarms or data log occurs.

NOTES: Analog I/O – Optional (DIN Rail Mount to CM)

Analog I/O (Input/Output):

Remote Setpoint: Cards accept two 4-20mA or 2-10Vdc inputs to be transmitted as SP values via the serial link to specific DIN controllers.

Retransmission: Cards have one 4-20mA or 0-10VDC signals configurable as PV, Setpoint or % Out values from specific DIN controls

Maximum number of cards is 7: 14 remote setpoint inputs and 7 retransmitted PV, Setpoint or %Output values.

NOTES: System Configuration

Orion-M has an embedded configuration program and normal runtime allowing full customization & configuration directly from the GUI. Simple Import/Export function allows complete configurations to quickly & easily imported to other Orion-M iSeries control systems.

Configuration Program allows:

- Number of Loop Controls, Monitor Points, Digital Inputs, Digital Outputs and Analog I/O.
- Assign Tag Names to Loop, Monitor, Alarms, System Events, Digital Input & Outputs
- Profile Setup: Time or Ramp Rate based Ramp configuration.
- Main View: Select Start up/Main View (home page)
- Menu System: Enable/disable specific Menu items & functions not required or desired for the application
- System Event Configuration to allow multiple DO from one Event

Runtime Configuration allows:

Profile Power Recovery logic, Setpoint Limits, Alarm Settings, LAN settings (VNC, Modbus, web server, email, FTP, alarm email / text), Barcode Reader, degrees C/F, DO counter, Date/Time, Help/Voice language selection, I/O mapping & logic, Monitor Point offset, Analog I/O configuration, export/import configuration & more.

NOTES: Loop Controls (Serial connection to CM)

Control Module (CM) Software for Loop Controls:

The software allows connection up to 15 loop controls and one FDC-IO monitor input module (8-T/C, 6-RTD or 8-mA or VDC inputs). (specific dual input loop controls may allow up to 30 PV inputs)

The software and appropriate loop control model is identified by the character description on the part number matrix. Note that the appropriate software must be specified for the Control Module memory.

The FD30 & FD10 CM software allows connection to Future Design Controls 300 & 100 Series DIN controllers. Both Series are available in 1/32, 1/16, 1/8 and 1/4 DIN sizes with DIN rail mounting available for both the 1/32 and 1/16 DIN sizes. Information on these Series controllers may be found at the following links:
<http://www.futuredesigncontrols.com/300.HTM>
<http://www.futuredesigncontrols.com/100.HTM>

CM software supporting Honeywell, Watlow, Danaher , Eurotherm, Yokagawa and other controller products are, or will be available. Refer to the specific FDC brochure available for each control brand as there may be limitations depending upon control brand.

OPTIONS: Manual, Screen Covers and USB/Ethernet Cables

Printed Operators Manual

<u>Part Number</u> (FDC-Orion-M_iSeries_Operators_Manual.pdf)	<u>Price</u>
FDC-Orion-M Operators Manual	\$30.00

Printed Configuration Manual

<u>Part Number</u> (FDC-Orion-M_iSeries_Config_Manual.pdf)	<u>Price</u>
FDC-Orion-M Configuration Manual	\$30.00

Color Touch Screen Protective Screen Covers

<u>(FDC-210_Series_Protective_Sheet.pdf)</u>	<u>Price</u>
PS2107 FDC-2107 7" Display / 5 per pack	\$30.00
PS2110 FDC-2110 10" Display / 5 per pack	\$30.00

USB Cables & Accessories

	<u>Price</u>
IStick-Panel USB Panel Mount Adapter	\$40.00
IStick-4X-CVR USB Panel Mount Adapter-Nema4x	\$75.00

Ethernet Cables

<u>Part Number</u>	<u>Price</u>	<u>Part Number</u>	<u>Price</u>
CA-CAT5E-Patch-7ft	\$10.00	CA-CAT5E-Crossover-7ft	\$10.00
CA-CAT5E-Patch-25ft	\$15.00	CA-CAT5E-Crossover-25ft	\$15.00
CA-CAT5E-Patch-50ft	\$25.00	CA-CAT5E-Patch-100ft	\$45.00

NOTES: Serial Communications (Serial connection to CM)

RS485 Modbus RTU (slave) and RS232 (barcode input) modules

RS485 Modbus RTU input module:

The RS485 module allows 3rd party software / hardware R/W access to specific registers within the Control Module. Contact Future Design Controls technical support for the register/address listing for specific software versions.

RS232 Serial input for barcode readers:

The RS232 serial input option allows the Orion to receive up to 16 characters from a standard compatible serial Barcode reader. Data from the bar code reader will insert operator events into the historical data file; there is no limit to the number of events that may be entered manually or with a bar code scanner.

Note: If Serial Communication is used the RS485 module must be included; i.e. if bar code reader is used both the RS485 and the RS232 (used for bar code reader) modules must be specified.

NOTES: Control Module (CM) components, I/O & other options

USB Memory Stick:

A high capacity USB Memory Card is provided to facilitate file transfer to and from the FDC-2107/2110 display. The USB memory card power requirement is 3VDC matching the display's USB port 3VDC power supply (note: many USB memory sticks require 5VDC and will not work with the FDC-2107/2110 display)

CM: CM components includes the following hardware:

- FC5A-D16RS1: CPU (IO includes 8-digital output & 8 input (DO 6-relay & 2-TTL 24VDC) & (DI 8 24VDC)
- CA2011-8A: Cable (8ft) to connect CPU to GUI
- FC4A-PM64: CPU memory card (CM application software pre-installed)
- FC4A-PT1: CPU Real Time Clock (RTC)
- FC4A-HPC3: Modbus port to connect control module to loop and monitor input devices
- PS5R-SD24: 24VDC power supply for Display & CPU
- USB Memory: high capacity USB memory stick (3VDC)
- GE1A-C10MA110/SR2P-06: Reset Timer with mounting Socket

Optional Digital I/O (plugs into CPU) (*note 1)

- FC4A-T16S3: 16-digital output card (24Vdc source)
- FC4A-R161: 16-digital output card (relay 240Vac 2A)
- FC4A-T08S1: 8-digital output card (24Vdc source)
- FC4A-R081: 8-digital output card (relay 240Vac 2A)
- FC4A-N08B1: 8-digital Input card (24Vdc)
- FDC4-N08A11: 8-digital input card (120Vac)

Maximum Digital IO Summary for CPU & optional IO modules

- Digital Output: 32 Digital Outputs
 CPU 8-digital out (6-relay and 2-transistor)
 Optional 24-digital out (relay or 24Vdc)
- Digital Inputs: 16 Digital Inputs
 CPU 8-digital in (24Vdc)
 Optional 8-digital in (120Vac or 24Vdc)

Optional Analog I/O (Remote SP & Retransmission) (*note 1)

- FC4A-L03A1 Two mA or Vdc inputs & one mA or Vdc out

Optional Serial Communication Modules (*note 1)

- FC5A-SIF2: RS232 port for Barcode Reader
- FC5A-SIF3: RS485 Modbus RTU (slave)

Optional Monitor Point 8-channel (6-channel RTD) input module

System supports one Monitor Input Module (serial connection to CM):

- IO-8TCS: 8-thermocouple input module (isolated)
- IO-6RTD: 6-RTD input module
- IO-8AIIS: 8- input module 0-20 / 4-20mA (isolated)
- IO-8AIVS: 8-analog input 0-10 / 2-10VDC (isolated)

*Note 1: CM will support up to 7 expansion modules.

(The Monitor Point input module is not a CM expansion module)

FUTURE DESIGN SOFTWARE LICENSE FOR FDC Orion-M Control System

Future Design Controls Windows CE based Orion display and Control Module (Idec PLC) software (listed as "SOFTWARE" in this document) is protected by copyright laws and international copyright treaties, as well as other intellectual property laws and treaties. The SOFTWARE is licensed at no charge to the end user when all components, including but not limited to the Control Module (Idec PLC components) and CE Color Touch Screen display are purchased from Future Design Controls. All ownership and rights remain with Future Design Controls.

I. LICENSE GRANT. This LICENSE grants you the following rights:

A. You may use Future Design's SOFTWARE with Future Design Controls products or products marketed by Future Design Controls only. Products are considered Future Design Controls products (and products marketed by Future Design Controls) when the sale or shipment originates from our main headquarters in Bridgeview, IL or one of our authorized office locations. Products purchased from Future Design Controls distributors or OEM's with brand labels other than Future Design controls are not considered Future Design Controls products and cannot be used with Future Design's SOFTWARE. Using Future Design's SOFTWARE with any other manufacturer (or distributor) of hardware is a violation of this license and applicable copyright laws. The SOFTWARE is considered in "use" when it is installed into permanent or temporary memory (e.g. CE display unit/PLC, or other storage device)

B. Solely with respect to electronic documents included with the SOFTWARE, you may make a copy (either in hardcopy or electronic form), provided that the software is not resold without the knowledge and acceptance of terms by Future Design Controls.

II. TITLE; COPYRIGHT.

All title and copyrights in and to the SOFTWARE (including but not limited to any images, photographs, animation, video, audio, music, text and "applets" incorporated into the SOFTWARE), the accompanying printed materials, and any copies of the SOFTWARE are owned by Future Design Controls or its suppliers. The SOFTWARE is protected by copyright laws and international treaty provisions. Therefore, you must treat the SOFTWARE like any other copyrighted material, except that you may either (A) make one copy of the SOFTWARE solely for backup or archival purposes or (B) install the SOFTWARE on each system purchase from Future Design Controls (CE display/PLC) provided you keep the original solely for backup or archival purposes. You may not copy the printed materials accompanying the SOFTWARE.

III. ADDITIONAL RIGHTS AND LIMITATIONS.

A. Reverse Engineering, De-compilation, and Disassembly: You may not reverse engineer, decompile, disassemble or modify the SOFTWARE (CE display software and/or Control Module (PLC) code).

B. No Separation of Components. The SOFTWARE is licensed as a single product and the software programs comprising the SOFTWARE may not be separated for use on any hardware not supplied by Future Design Controls.

C. Rental. You may not rent or lease the SOFTWARE.

D. Software Transfer. You may NOT transfer any of your rights under this LICENSE.

E. Termination. Without prejudice to any other rights, Future Design Controls may terminate this LICENSE if you fail to comply with the terms and conditions of this LICENSE. In such event, you must destroy all copies of the SOFTWARE and agree not to modify/distribute the software or download to any hardware not purchased from Future Design Controls.

F. The selection, application or use of Future Design products or software is the purchaser or user's responsibility. No claims will be allowed for any damages or losses, whether direct, indirect, incidental, special or consequential. In addition, Future Design reserves the right to make changes without notification to purchaser or user to materials or processing that do not affect compliance with any applicable specification. Future Design Controls makes no warranties when using Future Design Controls SOFTWARE system.

Software Usage Note:

The selection, application or use of Future Design Control products or software is the purchaser or user's responsibility. No claims will be allowed for any damages or losses, whether direct, indirect, incidental, special or consequential.

In addition, Future Design reserves the right to make changes without notification to purchaser or user to materials or processing that do not affect compliance with any applicable specification. Future Design makes no warranties when using the Orion-M system.

Warranty:

Future Design Controls products described in this book are warranted to be free from functional defects in material and workmanship at the time the products shipped from Future Design Controls facilities and to conform at that time to the specifications set forth in the relevant Future Design Controls manual, sheet or sheets for a period of one year after delivery to the first purchaser.

Future Design Controls FDC-2010 products are warranted to be free from functional defects in materials and workmanship at the time the products shipped from Future Design Controls facilities and to conform at that time to the specifications set forth in the relevant Future Design Controls manual, sheet or sheets for a period of one year after delivery to the first purchaser for use.

There are no expressed or implied Warranties extending beyond the Warranties herein and above set forth. Limitations: Future Design Controls provides no warranty or representations of any sort regarding the fitness of use or application of its products by the purchaser. Users are responsible for the selection, suitability of the products for their application or use of Future Design Controls products.

Future Design Controls shall not be liable for any damages or losses, whether direct, indirect, incidental, special, consequential or any other damages, costs or expenses excepting only the cost or expense of repair or replacement of Future Design Control products as described below.

Future Design Controls sole responsibility under the warranty, at Future Design Controls option, is limited to replacement or repair, free of charge, or refund of purchase price within the warranty period specified. This warranty does not apply to damage resulting from transportation, alteration, misuse or abuse.

Future Design Controls reserves the right to make changes without notification to purchaser to materials or processing that do not affect compliance with any applicable specifications.

Return Material Authorization:

Contact Future Design Controls for Return Material Authorization Number prior to returning any product to our facility:



7524 West 98th Place – Bridgeview, IL 60455 – Phone 888.751.5444 – Fax 888.307.8014

<http://www.futuredesigncontrols.com>